

# 4" Oil filled motors

## Dimensions and Weights :

### **DIMENSIONS AND WEIGHTS**

SINGLE-PHASE MOTORS 50Hz

P2		L	Weight	
kW	HP	mm	Kg	
0.37	0.5	348.5	7.80	
0.75	1.0	408.5	10.60	

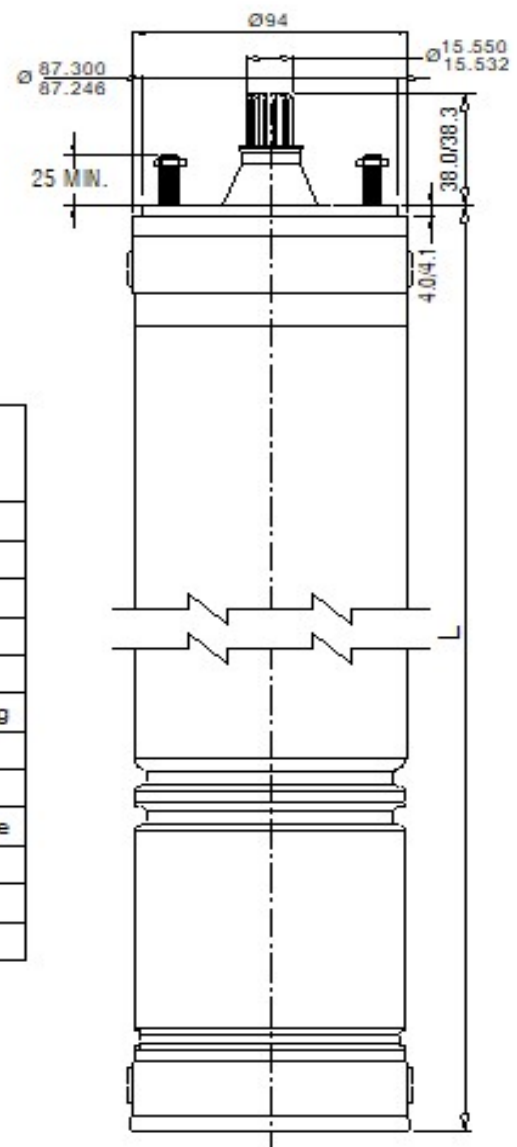

### MATERIAL SPECIFICATIONS

Component	Material
Motor Shell	Stainless Steel
Sand Guard	CR (Neoprene)
Stud	AISI 304
Upper Bearing Housing	Cast Iron
Mechanical Seal	Ceramic / Carbon
Oil Seal	CR (Neoprene) with S.S.Spring
Shaft	AISI 420
Rotor	Aluminium Die Cast
Winding	Enamelled copper winding wire
Lower Bearing Housing	Cast Iron
Thrust Bearing Housing	Cast Iron
Diaphragm Rubber	CR (Neoprene)

NOTE :-  
ALL DIMENSIONS ARE IN mm.  
SPECIFICATIONS SUBJECT TO CHANGE DUE TO CONTINUOUS IMPROVEMENT.